

Assembly Instructions

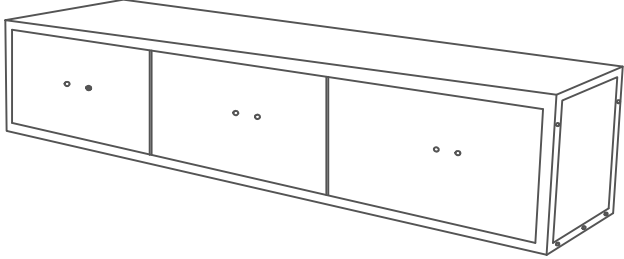

1280MC

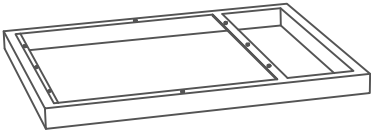
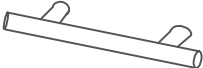

## Parts List

Label	Picture	Description	Qty
A			1
B			1
C			2
D			3

## Hardware List

Label	Picture	Description	Size	Qty
H-1		Bolt	M6x15 mm	12
H-2		Bolt	M6x55 mm	4
H-3		Bolt	M6x40 mm	6

## Tool List

Label	Picture	Description	Size	Qty
T-1		Allen Key	ø4 mm	1

# Assembly Steps

ATTENTION:

DO NOT COMPLETELY TIGHTEN ANY SCREWS UNTIL ALL PARTS ARE IN PLACE

## Step 1

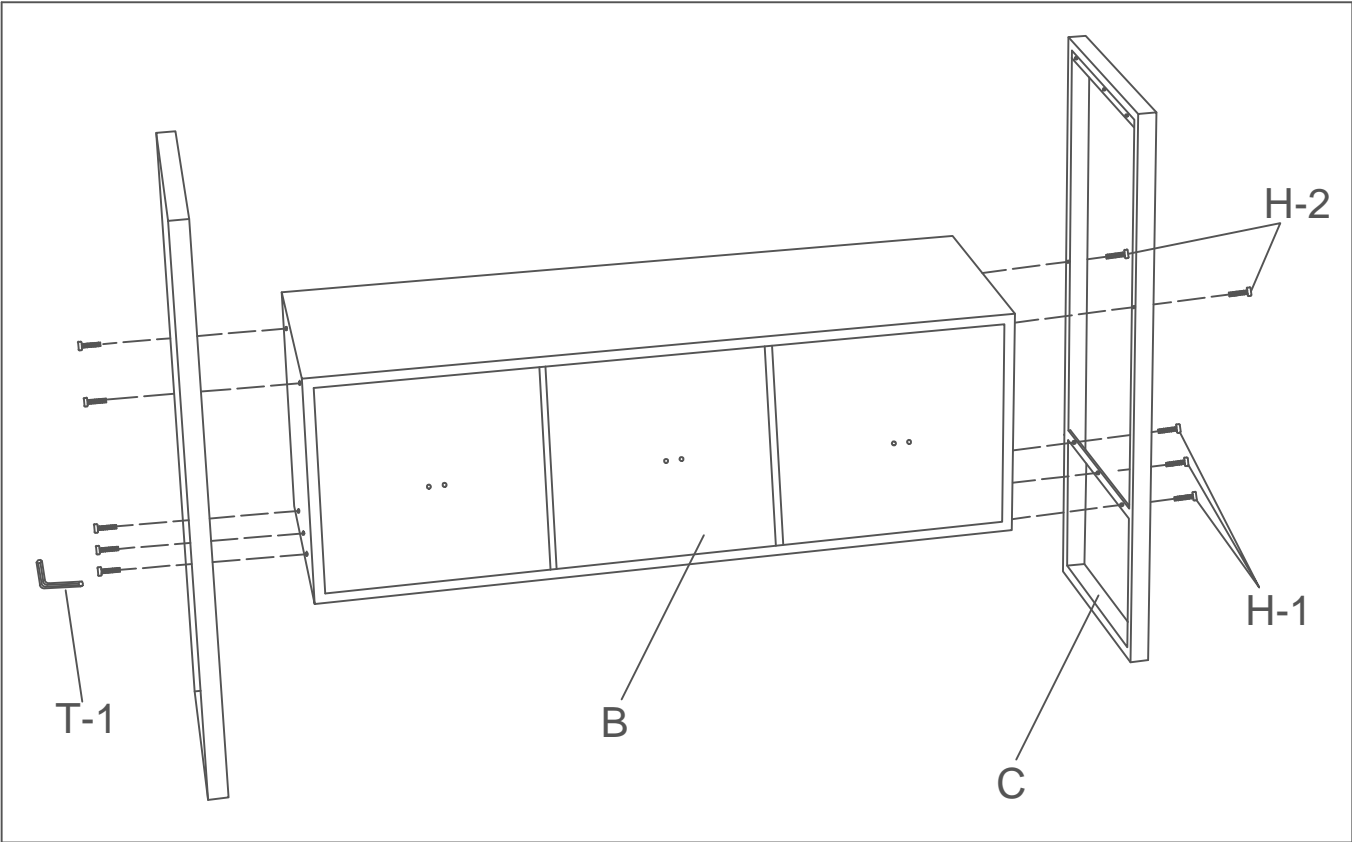

## Step 2

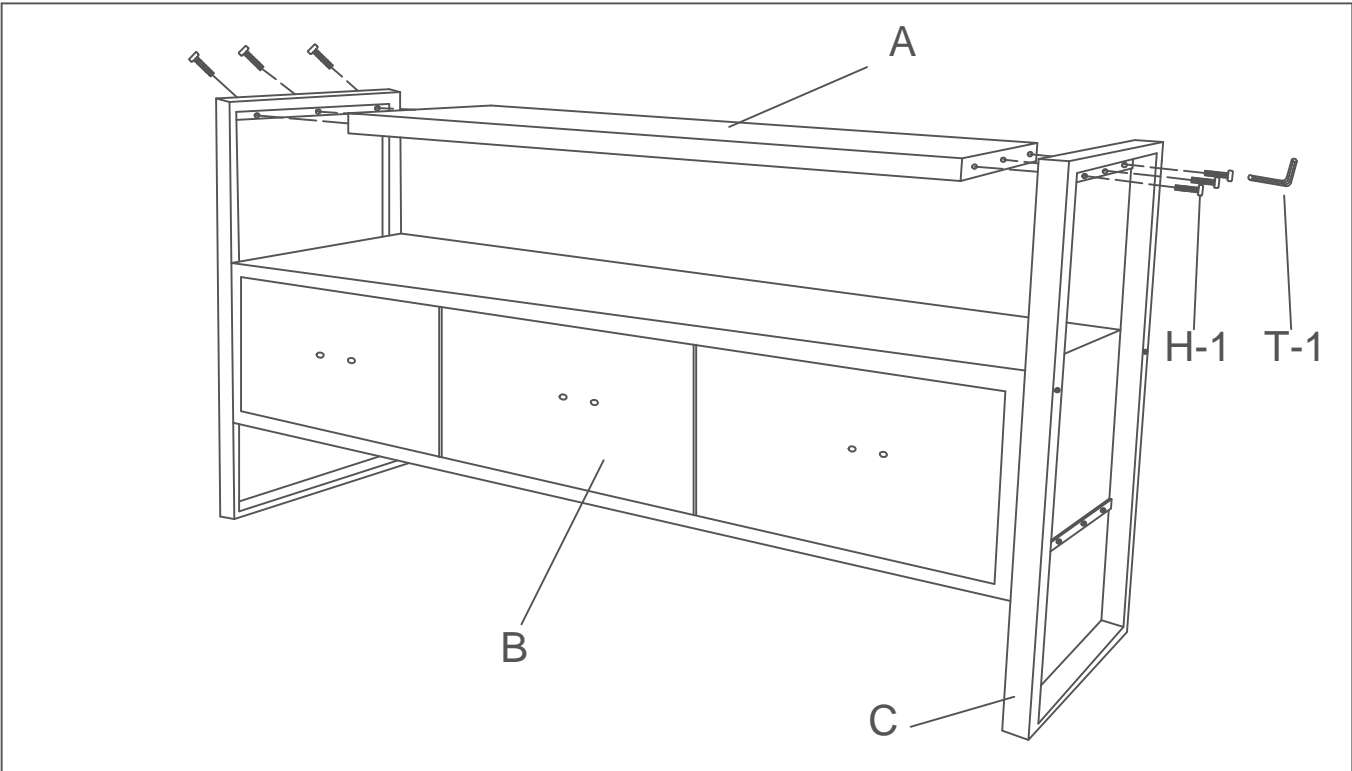

## Step 3

---

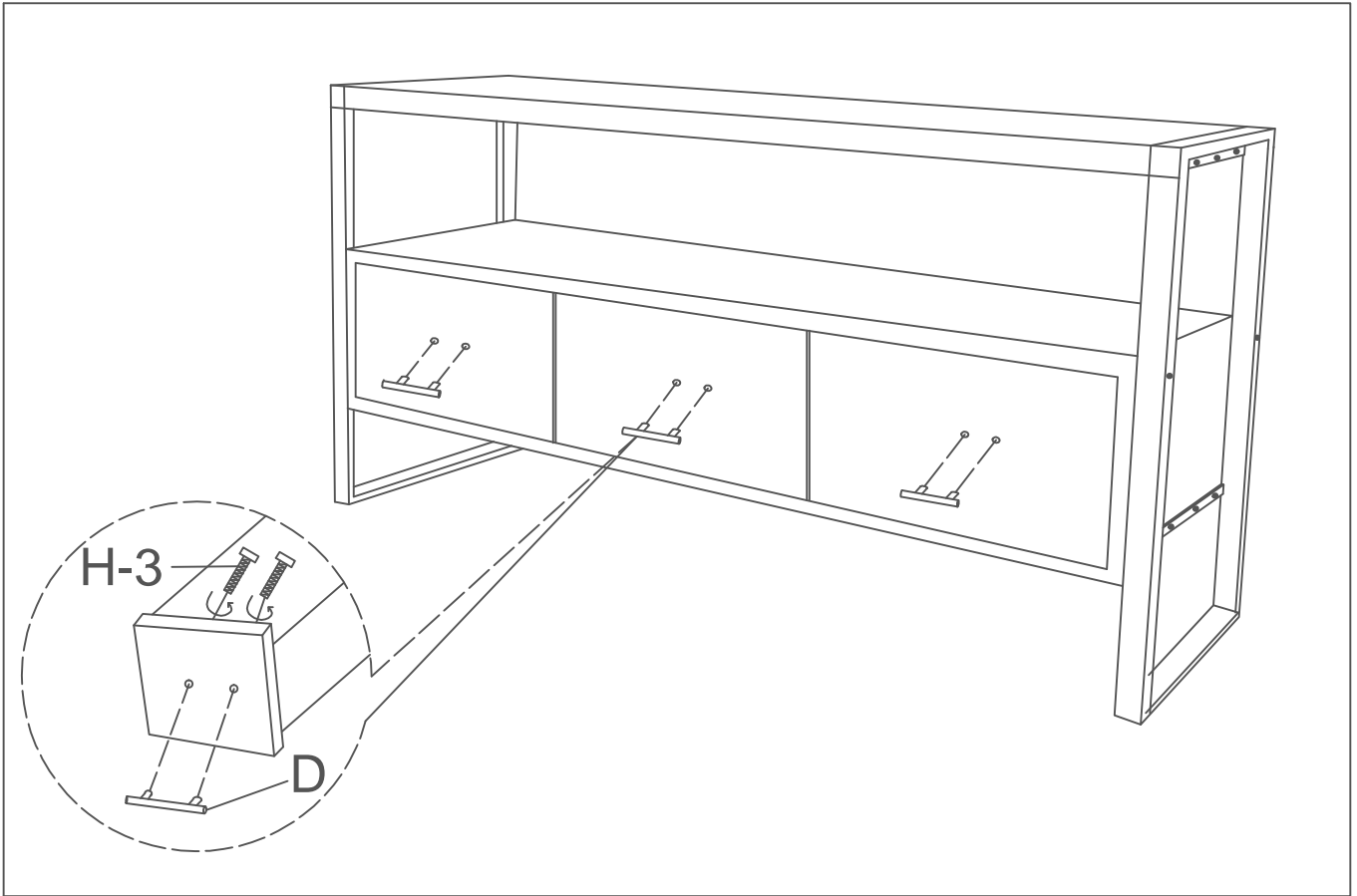

## Step 4

---

